

**Features**

- 2-channel isolated barrier
- 24 V DC supply (Power Rail)
- Dry contact or NAMUR inputs
- Selectable frequency trip values
- 2 relay contact outputs
- Start-up override
- Selectable mode of operation
- Line fault detection (LFD)
- Up to SIL 2 acc. to IEC 61508

**Function**

This isolated barrier is used for intrinsic safety applications. It is a zero speed/standstill monitor that accepts input frequency pulses and triggers an output when the frequency drops below a selected value.

Two startup override values are available. This unit can also be used to determine rotation direction.

During an error condition, relays revert to their de-energized state and LEDs indicate the fault according to NAMUR NE44.

The available diagnostic LEDs show rotation detection, limit trip indicator, power on, and hardware error indication.

The unit is easily programmed via switches mounted on the front of the unit.

A unique collective error messaging feature is available when used with the Power Rail system.

For additional information, refer to

**Assembly**

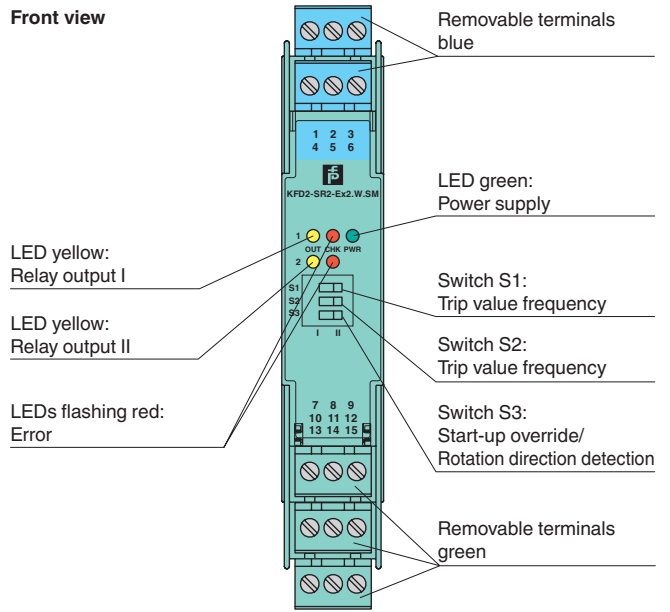

**SIL 2**

**Connection**

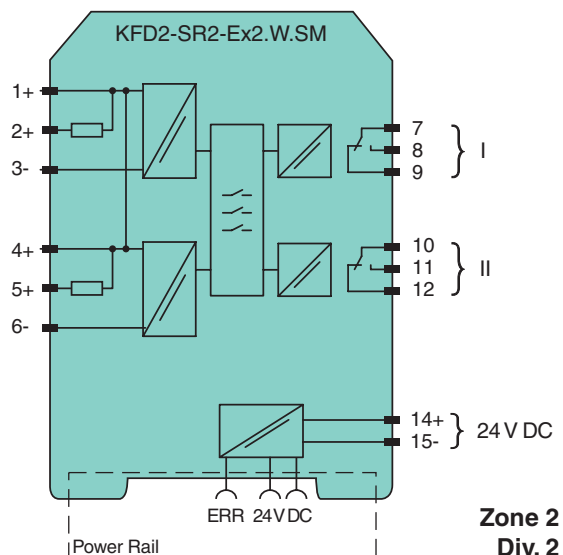
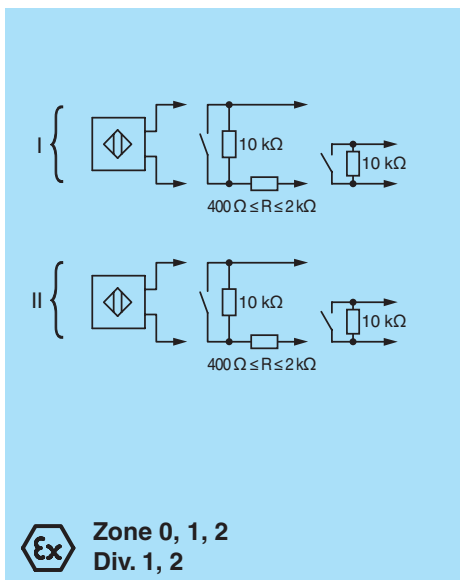

Release date 2018-06-19 07:42 Date of issue 2018-06-19 132964\_eng.xml

<b>General specifications</b>	
Signal type	Digital Input
Programming	via DIP switch and programmable
<b>Functional safety related parameters</b>	
Safety Integrity Level (SIL)	SIL 2
<b>Supply</b>	
Connection	Power Rail or terminals 14+, 15-
Rated voltage $U_r$	20 ... 30 V DC
Power consumption	≤ 1.5 W
<b>Input</b>	
Connection side	field side
Connection	Input I: terminals 1+, 2+, 3- ; Input II: terminals 4+, 5+, 6-
Rated values	acc. to EN 60947-5-6 (NAMUR)
Open circuit voltage/short-circuit current	approx. 8 V DC / approx. 8 mA
Switching point/switching hysteresis	1.2 ... 2.1 mA / approx. 0.2 mA
Line fault detection	breakage $I \leq 0.1$ mA , short-circuit $I > 6$ mA
Control input	sensor power supply approx. 8.2 V, impedance 1.2 kΩ
Pulse duration	> 200 μs for standstill monitoring, > 250 μs for rotation direction detection
<b>Output</b>	
Connection side	control side
Connection	output I: terminals 7, 8, 9 ; output II: terminals 10, 11, 12
Contact loading	253 V AC/2 A/cos φ > 0.7; 126.5 V AC/4 A/cos φ > 0.7; 40 V DC/2 A resistive load
Minimum switch current	2 mA / 24 V DC
Energized/De-energized delay	approx. 20 ms / approx. 20 ms
Mechanical life	10 <sup>7</sup> switching cycles
Trip value $f_{max}$	for standstill monitoring: 0.1 Hz; 0.5 Hz; 2 Hz; 10 Hz adjustable via DIP switch (S1 and S2)
<b>Transfer characteristics</b>	
Accuracy	5 % (S3 = I), 30 % (S3 = II)
Start-up override	5 seconds or 20 seconds, programmable
Frequency range	≤ 2 kHz
Rotation direction detection	90° phase difference between pulse input signal 1 and 2, overlapping ≥ 125 μs
<b>Galvanic isolation</b>	
Input/Output	reinforced insulation according to IEC/EN 61010-1, rated insulation voltage 300 V <sub>eff</sub>
Input/power supply	reinforced insulation according to IEC/EN 61010-1, rated insulation voltage 300 V <sub>eff</sub>
Output/power supply	reinforced insulation according to IEC/EN 61010-1, rated insulation voltage 300 V <sub>eff</sub>
Output/Output	reinforced insulation according to IEC/EN 61010-1, rated insulation voltage 300 V <sub>eff</sub>
<b>Indicators/settings</b>	
Display elements	LEDs
Control elements	DIP-switch
Configuration	via DIP switches
Labeling	space for labeling at the front
<b>Directive conformity</b>	
Electromagnetic compatibility	
Directive 2014/30/EU	EN 61326-1:2013 (industrial locations)
Low voltage	
Directive 2014/35/EU	EN 61010-1:2010
<b>Conformity</b>	
Electromagnetic compatibility	NE 21:2006
Degree of protection	IEC 60529:2001
Input	EN 60947-5-6:2000
<b>Ambient conditions</b>	
Ambient temperature	-20 ... 60 °C (-4 ... 140 °F)
<b>Mechanical specifications</b>	
Degree of protection	IP20
Connection	screw terminals
Mass	approx. 150 g
Dimensions	20 x 119 x 115 mm (0.8 x 4.7 x 4.5 inch) , housing type B2
Mounting	on 35 mm DIN mounting rail acc. to EN 60715:2001
<b>Data for application in connection with hazardous areas</b>	
EU-Type Examination Certificate	PTB 00 ATEX 2080

Release date 2018-06-19 07:42 Date of issue 2018-06-19 132964\_eng.xml

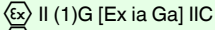
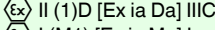
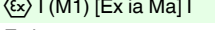
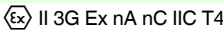
Marking		  
Input		Ex ia
Voltage	U <sub>o</sub>	10.5 V
Current	I <sub>o</sub>	13 mA
Power	P <sub>o</sub>	34 mW (linear characteristic)
Supply		
Maximum safe voltage	U <sub>m</sub>	253 V AC / 125 V DC (Attention! U <sub>m</sub> is no rated voltage.)
Output		
Contact loading		253 V AC/2 A/cos φ > 0.7; 126.5 V AC/4 A/cos φ > 0.7; 40 V DC/2 A resistive load
Maximum safe voltage	U <sub>m</sub>	253 V AC (Attention! The rated voltage can be lower.)
Fault indication output		
Maximum safe voltage	U <sub>m</sub>	40 V DC (Attention! U <sub>m</sub> is no rated voltage.)
Certificate		TÜV 99 ATEX 1493 X
Marking		
Output		
Contact loading		50 V AC/4 A/cos φ > 0.7; 40 V DC/2 A resistive load
Galvanic isolation		
Input/Output		safe electrical isolation acc. to IEC/EN 60079-11, voltage peak value 375 V
Input/power supply		safe electrical isolation acc. to IEC/EN 60079-11, voltage peak value 375 V
Directive conformity		
Directive 2014/34/EU		EN 60079-0:2012+A11:2013 , EN 60079-11:2012 , EN 60079-15:2010
<b>International approvals</b>		
FM approval		
Control drawing		116-0035
UL approval		
Control drawing		116-0145
CSA approval		
Control drawing		116-0047
IECEx approval		IECEx PTB 11.0034
Approved for		[Ex ia Ga] IIC, [Ex ia Da] IIIC, [Ex ia Ma] I
<b>General information</b>		
Supplementary information		Observe the certificates, declarations of conformity, instruction manuals, and manuals where applicable. For information see

### Operating principle

The function of standstill monitor with start-up override (S3 = I) or standstill monitor with rotation direction monitoring (S3 = II) can be selected by means of DIP switches.

S3:	I	II
<b>Function:</b>	Standstill monitor with start-up override	Standstill monitor with rotation direction monitoring
<b>Input I:</b>	Pulse input 1: NAMUR contacts (bounce-free)	Pulse input 1: NAMUR contacts (bounce-free)
<b>Input II:</b>	Start-up override: contact terminal 4 + 6: 20 seconds contact terminal 5 + 6: 5 seconds	Pulse input 2: NAMUR contacts (bounce-free)
<b>Output I:</b>	MIN/passive	MIN/passive
<b>Output II:</b>	MIN/active	Direction of rotation/error

#### Standstill monitor with start-up override (S3 = I)

If the frequency falls below the trip value set with the DIP switches S1 and S2, the standstill monitor with start-up override switches the output I to passive and the output II to active. Input I is used to monitor the frequency of rising current edges. Signal transmitters can be sensors in accordance with EN 60947-5-6 (NAMUR) or contacts. Input I is monitored for lead breakage/short-circuiting. A start-up override can be initiated via input II. The duration of the start-up override can be selected between 5 and 20 seconds by means of a bridge (starting trigger) or an external trigger signal. During the start-up override time the outputs assume the "no standstill" state. In this case there is no lead breakage/short-circuit monitoring at input II.

Trip value	Hysteresis	Switch S2	Switch S1
0.1 Hz	0.02 Hz	I	I
0.5 Hz	0.1 Hz	I	II
2 Hz	0.4 Hz	II	I
10 Hz	2 Hz	II	II

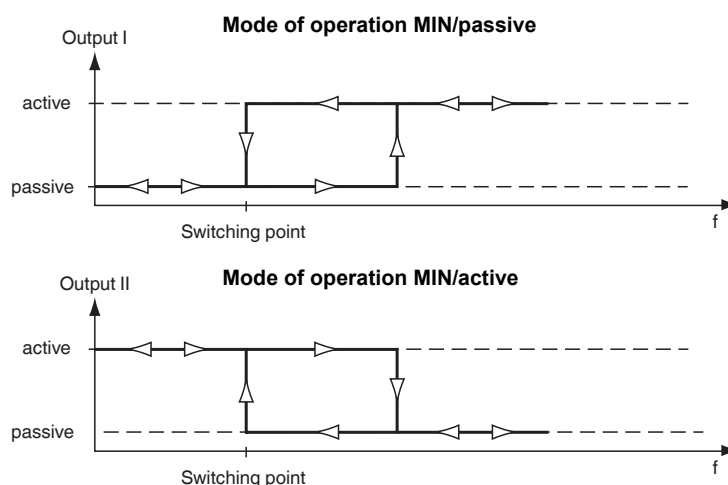

### Standstill monitor with rotation direction monitoring (S3 = II)

The device also offers stand still monitoring with direction of rotation monitoring as an alternative to stand still monitoring with start-up override. The trip values are identical to the standstill monitor with start-up override. At input II a signal that is offset by 90° to input I has to be applied; in this context minimum signal overlapping should be ensured. Signal transmitters at input I and input II can be sensors in accordance with DIN EN 60947-5-6 (NAMUR) or contacts. Both inputs are monitored for lead faults. Output I is used for standstill signalling and switches to a de-energized state (passive) in the event of a standstill. Output II is switched to active when the direction of rotation is clockwise. If a reverse rotation is detected or if a signal overlap is missing, output II switches to a de-energized state (passive). In this case it can be concluded, that the sensor is misadjusted or defective. If the sensor at input I is misadjusted or defective, input II is used for standstill monitoring.

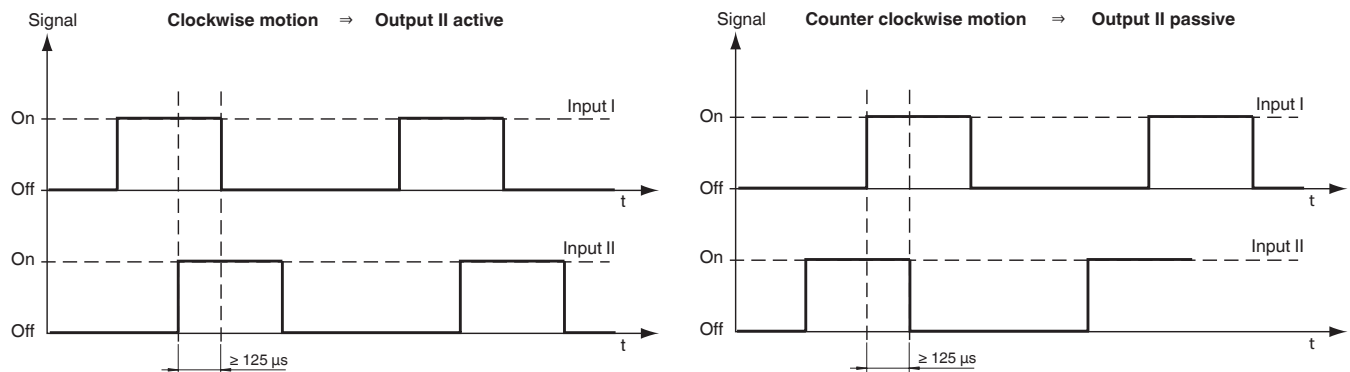

#### Behaviour during malfunction:

- Monitoring for lead faults
- Continuous monitoring of the device for errors in internal memory

If an error occurs, both relays go into the secure state, the red LEDs indicate the error and a collective error message is generated via the Power Rail.

#### Advice on use in SIL2 applications (Functional safety)

Care should be taken to ensure that the relays are de-energized (passive) in the critical condition of the application. Then, in the event of a power failure (de-energized, passive relay) the safety-critical state (energized) relay cannot be achieved.

##### Example 1:

The protective guard for a rotating shaft must remain locked in position until the shaft has stopped rotating. The safety-critical condition is the rotation of the shaft (risk of injury). For this reason, the locking of the protective guard should be achieved by means of a de-energized (passive) relay. The relay shall be energized (active) only when the shaft has stopped (safe condition). This device function is only achieved with "Standstill monitoring with start-up override" (S3 = I) and control of the protective guard with relay 2.

##### Example 2:

The cooling of a critical process by means of fans/coolant pumps has to be monitored. The safety-critical condition is the standstill of the fans/pumps (overheating). For this reason an alarm must be triggered when a relay has de-energized (passive). As long as the fans or the pumps are running (safety condition) the relay is energized (active). This device function can be achieved with "Standstill monitoring with start-up override" (S3 = I) and "Standstill monitoring with direction of rotation signalling" (S3 = II) with relay 1.

**Maximum switching power of output contacts**

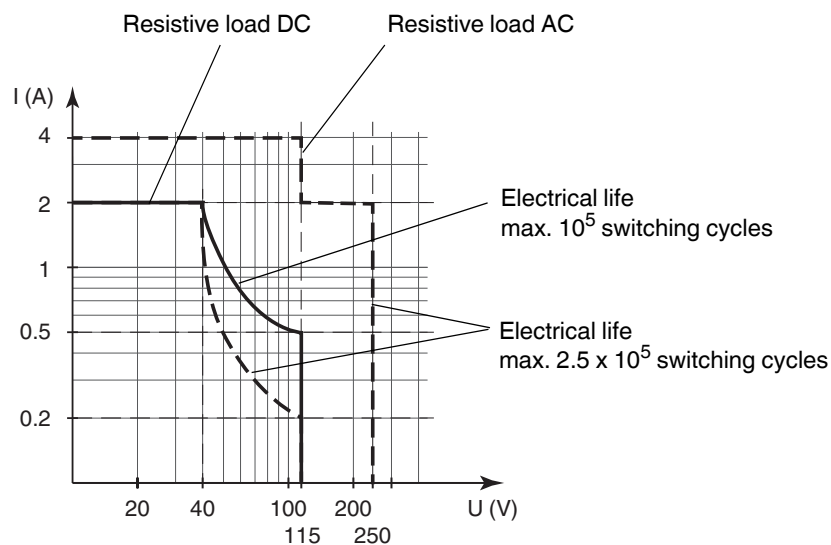

The maximum number of switching cycles is depending on the electrical load and may be higher when reduced currents and voltages are applied.

**Accessories**

**Power feed module KFD2-EB2**

The power feed module is used to supply the devices with 24 V DC via the Power Rail. The fuse-protected power feed module can supply up to 150 individual devices depending on the power consumption of the devices. Collective error messages received from the Power Rail activate a galvanically-isolated mechanical contact.

**Power Rail UPR-03**

The Power Rail UPR-03 is a complete unit consisting of the electrical insert and an aluminium profile rail 35 mm x 15 mm. To make electrical contact, the devices are simply engaged.

**Profile Rail K-DUCT with Power Rail**

The profile rail K-DUCT is an aluminum profile rail with Power Rail insert and two integral cable ducts for system and field cables. Due to this assembly no additional cable guides are necessary.



*Power Rail and Profile Rail must not be fed via the device terminals of the individual devices!*